

2" & 5" Lock Open Tool

ROV Tools.

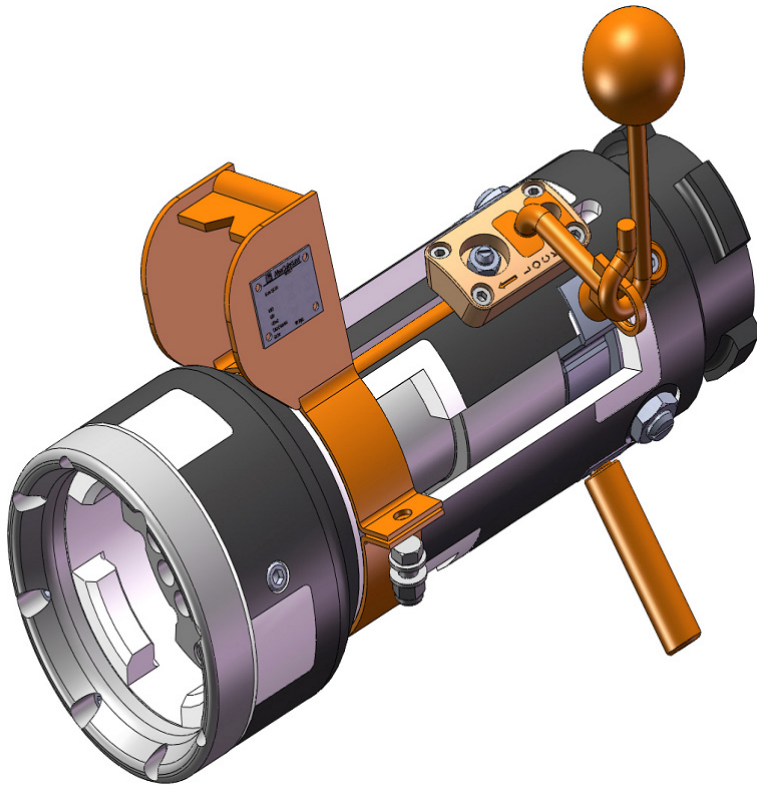

DESCRIPTION

FORUM has developed a tool to lock open linear valve interfaces. The tool is designed to suit the ISO 13628-8 Type A interface. The tool supplied is usually used in conjunction with an actuator tool. The actuator contains a hydraulically operated piston powered by an intensifier. Actuators can be supplied with hot stabs and check valves. The locking head is a purely mechanical device and is left behind on a subsea interface when the valve is required to be let overridden. The tool is manipulator operated. The advantage of the mechanical lock is that it will hold its position indefinitely as opposed to hydraulic systems that creep over time.

FEATURES

ISO 13628-8 Dec 02 Figure 15 Type A

Rated to 75 Tonne Force

5" Stroke

External stroke indicator

Guide nose

Lock to lock tool to tree.

Supplied in offshore suitable transit case.

2" & 5" Lock Open Tool

ROV Tools.

SPECIFICATIONS

Weight in air	52kg
Materials	17-4PH body Acetal guide nose
Handle	D-type (replaces T-bar & Fish Tail)

WHAT'S IN THE BOX

Lock Open Tool
Operations & Maintenance Manual.

PART NUMBERS & OPTIONS

A036-049-701	2" Lock Open Tool
A036-049-501	5" Lock Open Tool
A036-049-950	Lock Open Tool Actuator