

REVISION: 0	TITLE: FLUID ASSY, 600HP 3" (1 GAUGE CONN)		
DATE: 07/06/2010	DWG NO. PFA600-3.00		
ECN NO.:	CHANGES INCLUDE:		
ECN DATE:	DRAWN BY: KB	CHK'D: JF	APPV'D: SR
WEIGHT: 1532.66 lbs	SHEET 1 OF 2		
THIS DRAWING IS PROPRIETARY AND CONFIDENTIAL PROPERTY. THIS DOCUMENT CANNOT BE DISTRIBUTED OR REPRODUCED WITHOUT THE WRITTEN CONSENT OF PHOINIX GLOBAL LLC.			

ITEMS 21-28 DIAPHRAM SEAL
COMPONENTS SOLD SEPARATELY

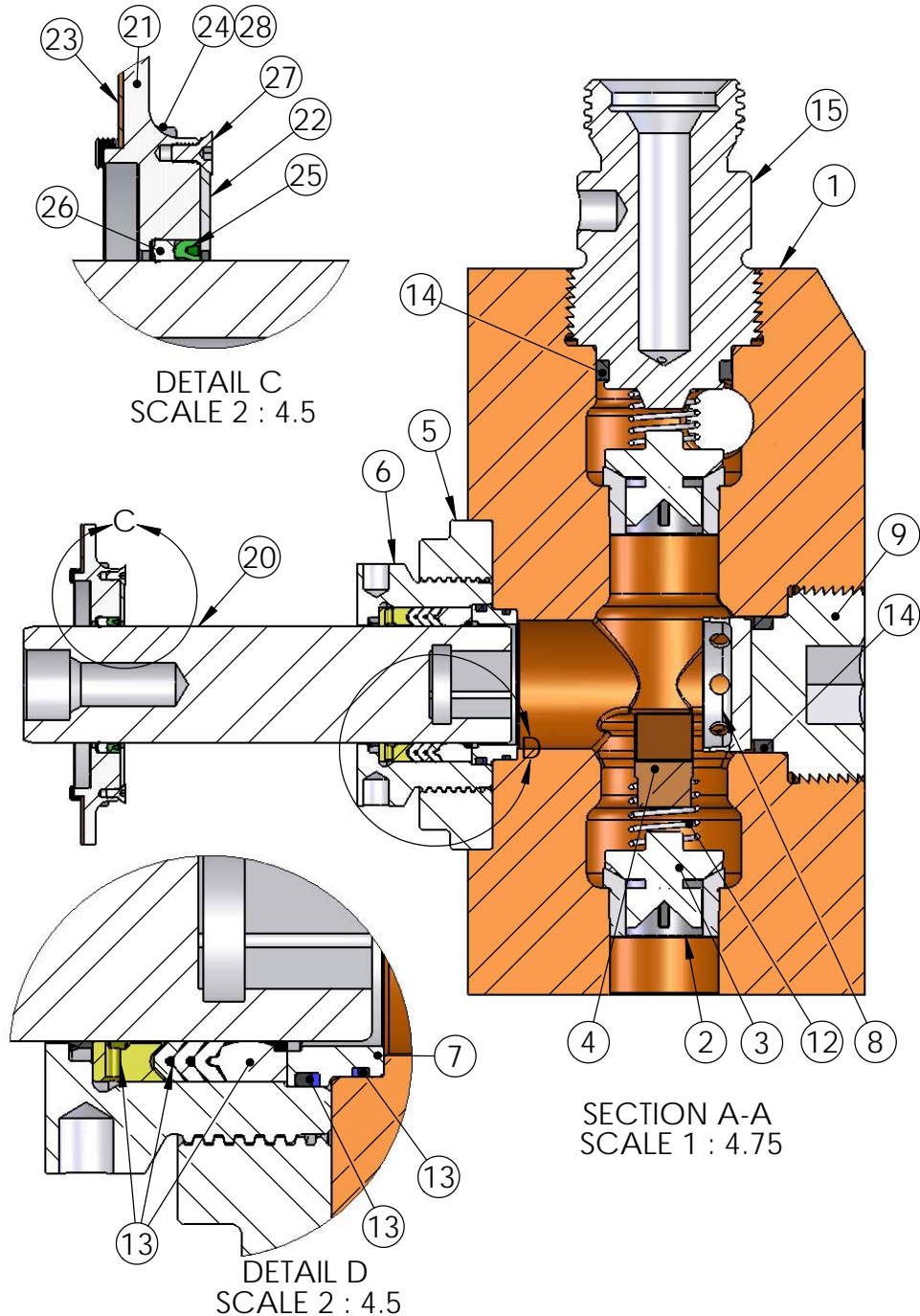

ITEM NO.	PART NUMBER	DESCRIPTION	QTY.
1	PFC-004-S	FLUID END CYLINDER, 600HP SMALL	1
2	PFC-014S-S	VALVE SEAT, 600HP SMALL	6
3	PFC-014V-S	VALVE COMPLETE, 600HP SMALL	6
4	PFC-007-S	VALVE STOP, 600HP SMALL	3
5	PFC-013-S	FLUID END ADAPTER, 600HP SMALL (2.75"-3")	3
6	PFC-012-3.00	PACKING NUT, 600HP 3.00"	3
7	PFC-005-3.00	STUFFING BOX ADAPTER, 600HP 3.00"	3
8	PFC-010-S-1	SUCTION COVER NUT CAGE, 600HP SMALL	3
9	PFC-010-S	SUCTION COVER NUT, 600HP SMALL	3
10	F-SHCF0.50-13X1.0-G5	CAP SCREW, SOC HD FLAT 1/2"-13 x 01.00"LONG GRADE 5	6
11	PFC-009-S	DISCHARGE COVER NUT, 600HP SMALL	2
12	PFC-015	VALVE SPRING, 600HP SMALL 7.5#	6
13	PFPC-600-3.00	PUMP PACKING COMPLETE, 600HP 3.00" NBR	3
14	PS600-CNS-SM-S01	COVER NUT SEAL, 600/1000HP SUCT/DISCH (SMALL) STD	6
15	PFC-002-S	GAUGE CONNECTION, 600HP SMALL	1
16	PFC-001	DISCHARGE FLANGE, 2" 1502F (600 HP PUMP)	1
17	PFC-011	DISCHARGE FLANGE-BLIND, 600HP	1
18	F-AT1.00-8X3.50-G8	FLANGE STUD, 1.00-8X3.50-G8	8
19	F-HN1.00-8-G8	HEX NUT, 1"-8 GRADE 8	8
20	PFC-006-3.00	PLUNGER, 600HP 3.00"	3
21	PFC-017-3.00	DIAPHRAM PLATE, 600HP 3.00"	3
22	PFC-019-3.00	DIAPHRAM SEAL RETAINER, 600HP 3.00"	3
23	PFC-018	DIAPHRAM GASKET, 600HP	3
24	F-HHC0.38-16X0.75-G8	CAP SCREW, HEX HD 3/8"-16 x 0.75"LONG	12
25	PFS-004-3.00	SEAL DIAPHRAM OUTER, 600HP 3.00"	3
26	PFS-005-3.00	SEAL DIAPHRAM INNER, 600HP 3.00"	3
27	F-SHCF0.25-20X0.5-G5	CAP SCREW, SOC HD FLAT 1/4"-20 x 00.50"LONG GRADE 5	12
28	F-WLS-0.38	WASHER, LOCKING STD 3/8"	12



REVISION:	0	TITLE:	FLUID ASSY, 600HP 3" (1 GAUGE CONN)
DATE:	07/06/2010	DWG NO:	PFA600-3.00
ECN NO.:		CHANGES INCLUDE:	
ECN DATE:		DRAWN BY:	KB
		CHK'D:	JF
		APPV'D:	SR
			SHEET 2 OF 2
WEIGHT:	1532.66 lbs	THIS DRAWING IS PROPRIETARY AND CONFIDENTIAL PROPERTY. THIS DOCUMENT CANNOT BE DISTRIBUTED OR REPRODUCED WITHOUT THE WRITTEN CONSENT OF PHOENIX GLOBAL LLC.	