

Specifying Zy-Gear Worm Gear

When ordering worm gears pre-bored and keyed from the factory, the following information must be provided.

1. Maximum torque required
2. Gear type: WG008, 108, 208, 308 or 408
3. Bore and keyway size with tolerances. Specify key shape, square or rectangle in width x width.
4. Location of keyway, A, B, C or D (see diagram)
5. Mounting pattern in ISO 5211 or MSS SP101 F numbers or special patterns, metric or inch thread holes
6. Handwheel sizes, 18", 24" or 30" diameter

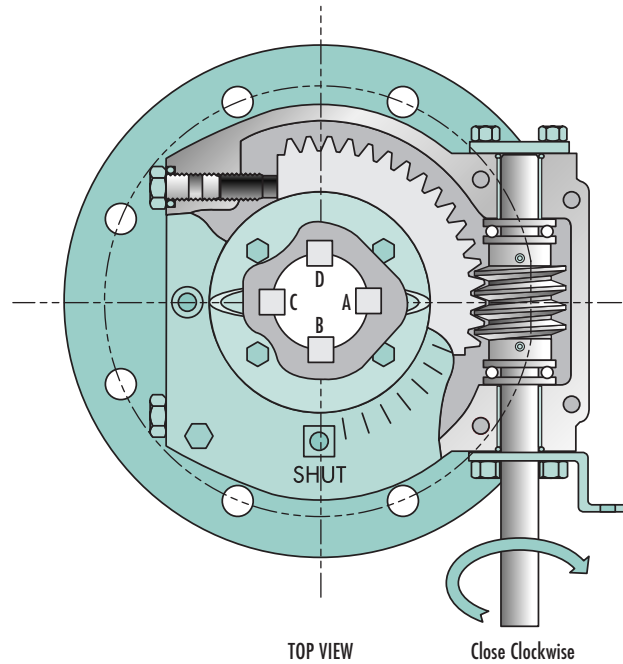

Zy-Gear Technical Formulas

Basic Formulas

Mechanical Advantage (MA) = Output torque/Input torque

Overall mechanical efficiency = MA of spur gear x MA of worm gear

Input torque = Output torque/MA

Output torque = Input torque x MA

Efficiency % = [Output torque x 100]/[Input torque x Gear ratio]

Overall Efficiency % = [Spur efficiency x worm efficiency] / 100

Ratio = Number of turns of input/Number of turns of output

Overall ratio = Spur gear ratio x Worm gear ratio

Number of turns to close = Gear ratio/4

Closing time (min.) = Number of turn to close/Input speed (RPM)

Closing time (sec.) = Number of turns to close x 60/Input speed (RPM)

Input speed (RPM) = Number of turns to close/Closing time (min.)

Number of turns to close = Input speed (RPM) x Closing time (min.)

Torque = Force x Radius

Input torque = [Handwheel rim effort x Handwheel diameter] / 2

Handwheel rim effort = [Input torque x 2]/Handwheel diameter

Handwheel diameter = [Input torque x 2]/Handwheel rim effort

NOTE: Units must be consistent within the formula.

Conversion Factor for Force

Multiply	By	To Obtain
Pound - Force	4.44822	Newton (N)
Newton (N)	0.22481	Pound - Force
Newton (N)	0.10197	Kilogram - Force
Kilogram - Force	9.8066	Newton (N)

Conversion Factor for Torque

Multiply	By	To Obtain
Pound - Foot	1.3558	Newton - meter (Nm)
Newton - meter (Nm)	0.73756	Pound - Foot
Newton - meter (Nm)	0.10197	Kilogram - meter
Kilogram - meter	9.8066	Newton - meter (Nm)