



# Merlin Water Jet Suction System

The excavation pump will not block or jam because there are no moving parts in the suction flow path. The flow reversal valve can be operated to back flush the suction nozzle should there be an obstruction. Power is derived from a stream of high velocity fluid creating a low pressure region behind the suction nozzle. The pump may be rapidly switched from suction to jetting, or be configured to an intermediate position allowing jetting and excavation to be carried out simultaneously.

## Features.

- Jetting and Excavation
- 1" Jetting Hose
- 4" Excavation Hose

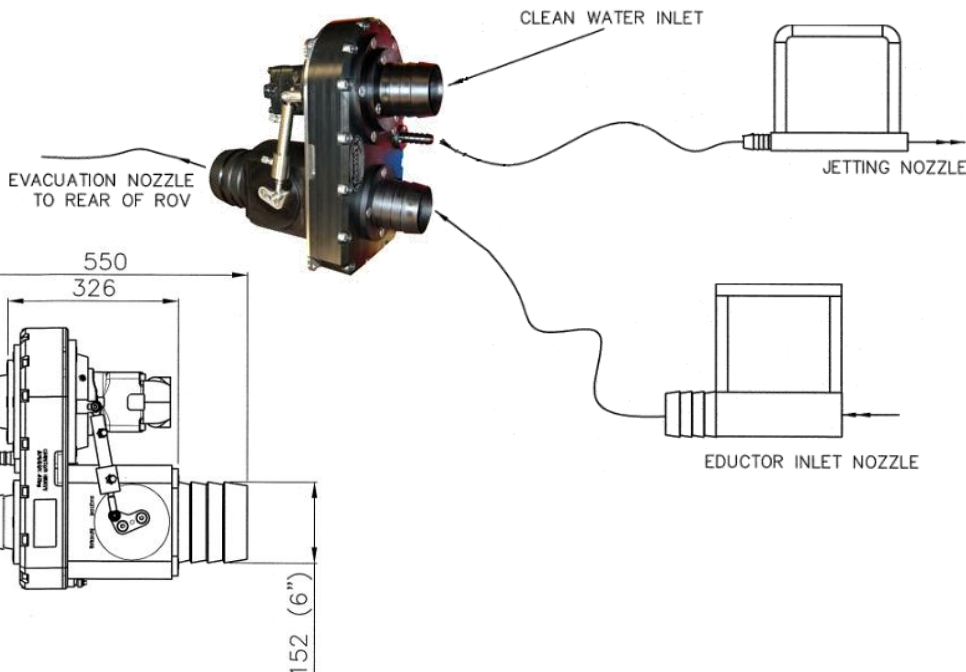

OVERALL DIMENSIONS  
292

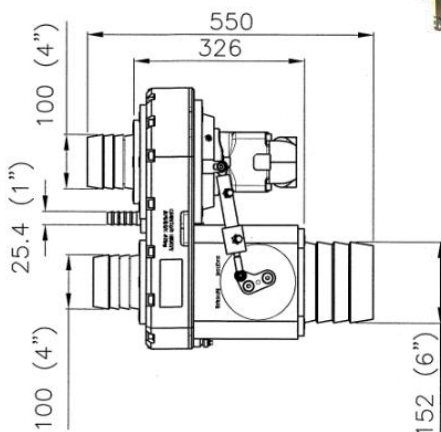
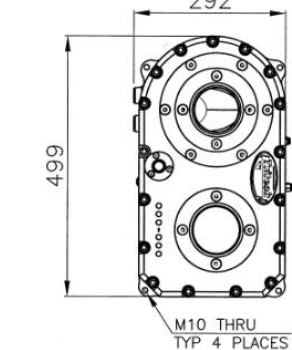

## Specifications.

Pressure Input	170 to 250 Bar (2,450 to 3,600PSI)
Flow Input	65 to 110lpm (16 USgpm)
Jetting	Up to 600lpm @8 Bar (160US gpm @ 115psi)
Suction Flow	2000-4000 lpm (500-1000 US gpm)
Solids Removal Rate	10-40 tonnes/hour (350-1500 lb/min)
Weight in air	40kg (90lb)
Weight in water	17kg (38lb)

Data Sheet: A001-350-140 issue 1

## What's included.

- A063-044-101**
- Tritech Merlin Pump
  - Jetting Nozzle
  - Eductor Nozzle
  - Connection Hoses
  - Kit to fit to TXLX

## Optional Extras.

A063-044-101/spares      Basic Spares Kit.

Data Sheet: A001-350-140 issue 1

The specification details are illustrative for marketing purposes only. Actual equipment may be different as a result of product improvement or other reasons. Specific interface and performance information should be reconfirmed at time of order placement.