

Comex Grab Skid.

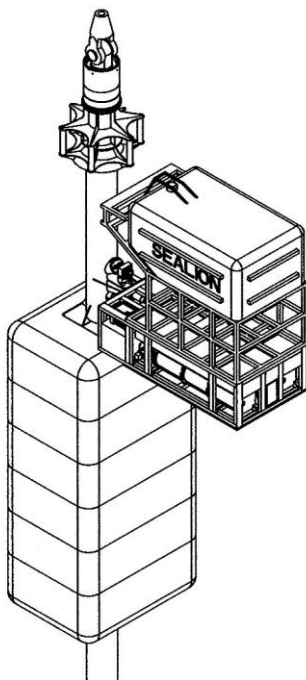

Project Summary

- Bespoke Work Skid to Fit Fugro Sealion.
- Used to aid recovery of cargo from sunken ship.
- Delivery Aug 2006
- 2 off 90L reservoirs.
- IHPU
- Smart Manifold
- Sea water boost pump.
- QD's and docking latches to interface with mechanical grab.
- Top Level part #A285-005-002

The client approached PSSL with the requirement for a work skid to control a large underwater mechanical grab. The grab was previously controlled from a dedicated control system but for reasons of reliability and operational simplicity a standard ROV system was employed. The work skid provides the additional fluid to control the grab and also a control system to control all functions on the skid.

PSS Drawing Number A001-350-110 iss 1

The specification details are illustrative for marketing purposes only. Actual equipment may be different as a result of product improvement or other reasons. Specific interface and performance information should be reconfirmed at time of order placement.