

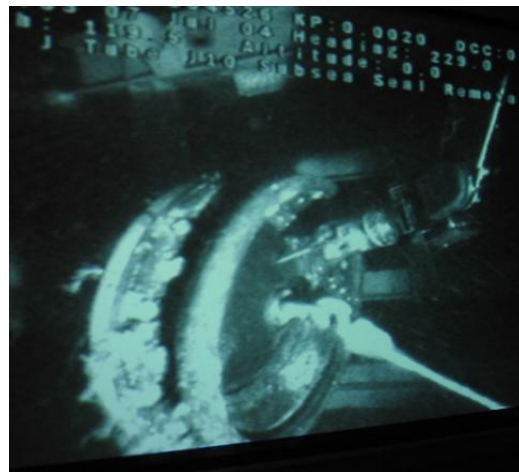

J-Tube Diaphragm Seal Cutter .

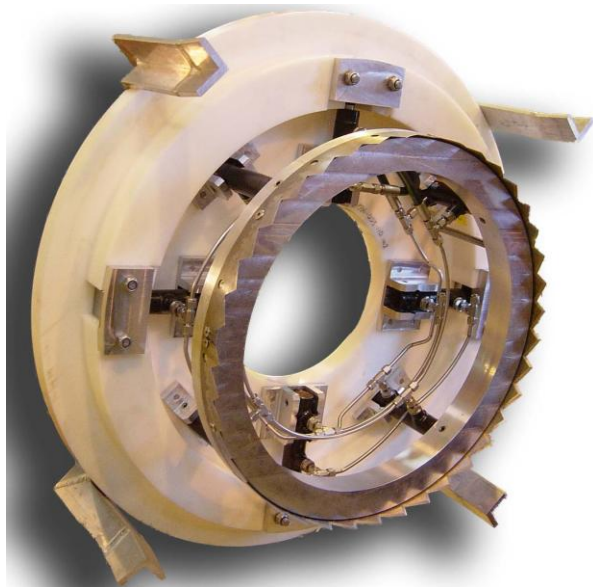

Project Summary

- Client: CTC
- Delivery Date: August 2004
- PSS Part Number A036-053-002
- Hydraulically Operated Cutting Tool.
- Light weight design to allow fitment to Panther ROV

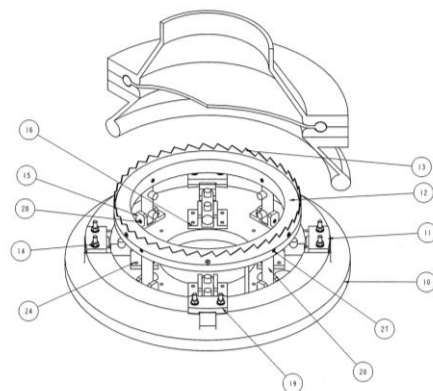

CTC contracted PSSL to provide a solution for removing a Diaphragm that had been accidentally left in place during deployment of the J-Tube. All previous attempts of removing the diaphragm by force had not succeeded. The ROV operations picture above shows a combined attempt of cutting and pulling on the diaphragm.

The entire project was completed in four weeks. A mock up of the mounting for the diaphragm was fabricated and a trial cut carried out on a diaphragm. This was a complete success and the tool was promptly dispatched offshore.

PSS Drawing Number A001-350-104 iss 1

The specification details are illustrative for marketing purposes only. Actual equipment may be different as a result of product improvement or other reasons. Specific interface and performance information should be reconfirmed at time of order placement.