



22.5" Suction Pile Venting System

The 22.5" Suction Pile Venting System is designed to provide primary venting of suction piles during self penetration and sealing during pump assisted penetration and extraction. The receptacles are welded to the top of the pile. The plug sits in the parking receptacle until it is needed to seal the receptacle (vent).

Features

- Pressure Tested to 10Bar (150psi)
- J-Slot locking grooves.
- Test fixture integral to receptacle.
- Pivoted stainless steel handle



22.5" Suction Pile Receptacle with 22.5" Suction Pile Plug Fitted

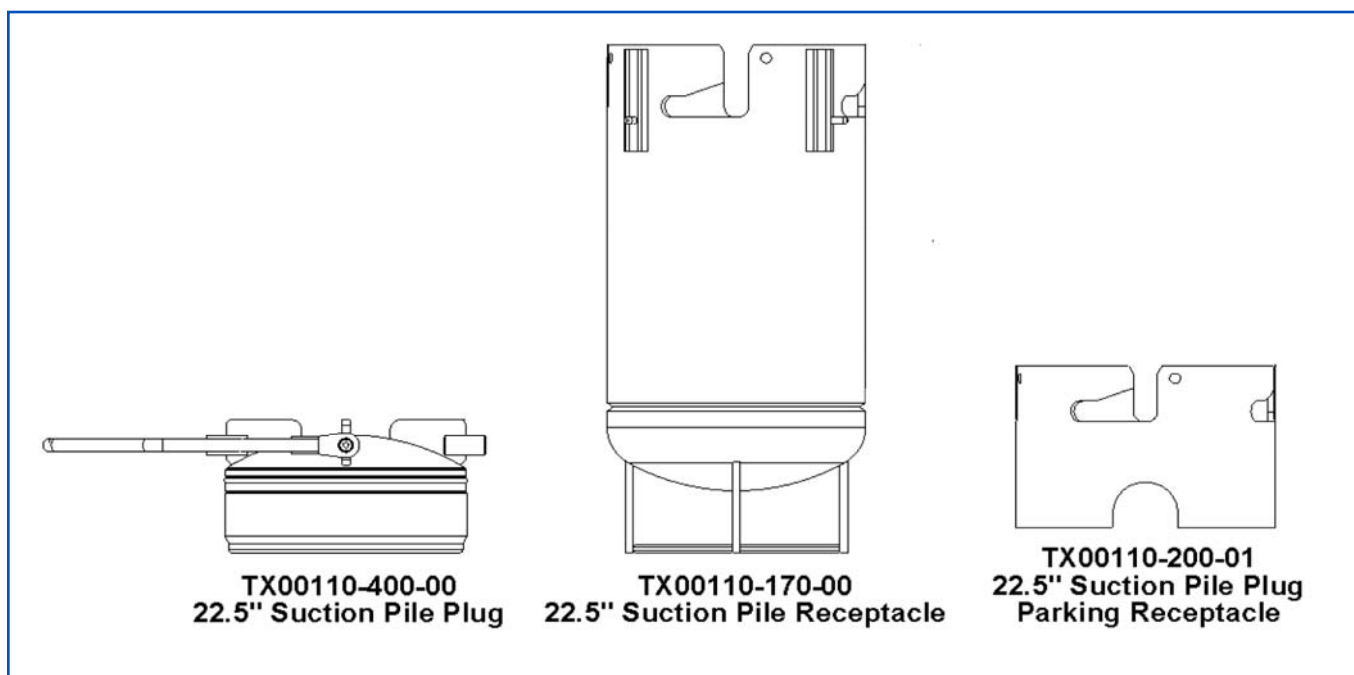

Specifications		Options
Suction Pile Plug		■ Alternative sizes available.
Space Envelope	Dia 572 x 332 (Dia22.5" x 13"-1/16)	
Weight in Air	~80kg(177 lbs)	
Weight in water	~45kg(100 lbs)	
Test Pressure	10 Bar (150psi)	
Material	Stainless Steel. HDPE/UHMW	
Suction Pile Receptacle		
Space Envelope	Dia 610 x 1267 (Dia 24" x 49"-7/8)	
Weight in Air	~356kg(785 lbs)	
Test Pressure	10 Bar (150psi)	
Material	Coated Carbon Steel	
Suction Pile Plug Parking Receptacle		
Space Envelope	Dia 610 x 406 (Dia 24" x 16")	
Weight in Air	~80kg(177 lbs)	
Material	Coated Carbon Steel	
Data Sheet: A001-350-088 issue 3		

The specification details are illustrative for marketing purposes only. Actual equipment may be different as a result of product improvement or other reasons. Specific interface and performance information should be reconfirmed at time of order placement.

