



Wellhead Cleaning Tool

The Motorized Wellhead Cleaning Tool is designed to clean the seal surface of wellheads that use AX or VX gaskets. The ROV powers the tool and holds it in position to remove debris. Flow regulator valves limit the rotation speed while still allowing high torque.

Features

- Stainless steel handle
- Simple scrubbing pad replacement
- Light weight aluminium and plastic construction.

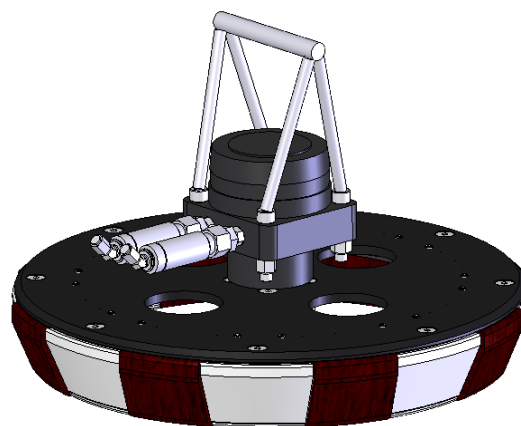

Part Number

TX00103-200-00

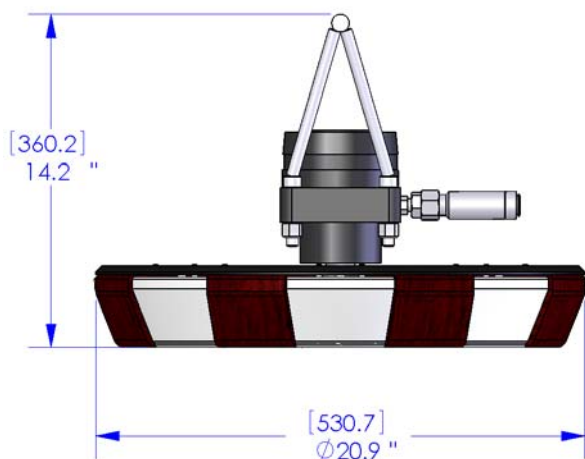

Specifications		Options
Input Pressure:	138 to 207 bar (2000 to 3000 psi)	<ul style="list-style-type: none"> ■ Alternative Sizes
Input Flow:	+5.7lpm(1.5+GPM)	
Dry Weight:	~ 24kgs (~52 lbs)	
Wet Weight:	~ 16kgs. (35 lbs)	
Cleaning Depth:	Approximately 1-7/8" (48mm)	
Materials:	Aluminum, UHMW/HDPE, Stainless Steel, plastic abrasive pads	
To suit:	18-3/4" AX/VX wellhead interface	
Data Sheet: A001-350-087 issue 3		

The specification details are illustrative for marketing purposes only. Actual equipment may be different as a result of product improvement or other reasons. Specific interface and performance information should be reconfirmed at time of order placement.