



Class 1-4 Bucket Lift Tool

The bucket lift tool is designed for subsea lifting operations on objects with vertical torque tool buckets.

It is a manually operated tool. Subsea, it is operated by robotic manipulator. The tool is operated by turning the paddle handle by 90 degrees. The handle has a detent mechanism to guard against accidental operation. Once a load has been picked up the handle cannot be turned, preventing accidental release of the load.

Features

- ISO 13628-8 Class 1-4 Bucket
- 500 kg Lift Capacity
- 3g Snatch Proof Tested
- Manipulator Controlled

Standard Tool

Part # A036-051-002



Dimensions

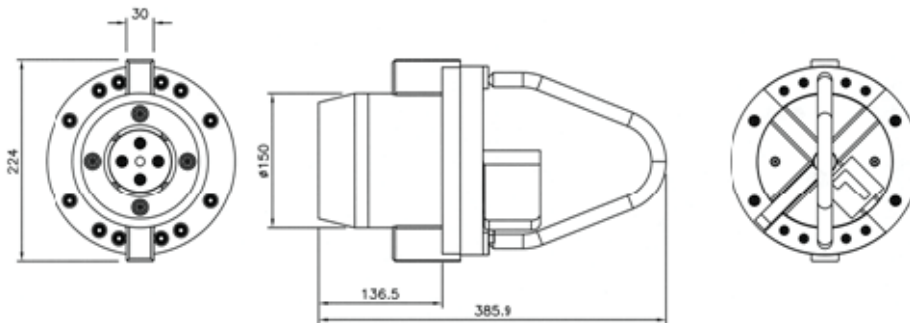

Specification

Interface:	ISO 13628:8 (E) Fig 18 Class 1-4, Fig 13
Safe Working Load (SWL):	500 kg
Design Rating:	3g Snatch (proof tested at 1500 kg)
Weight in Air/Water:	10 kg / 7 kg
Materials:	Marine grade aluminium, Stainless steel and acetal

Data Sheet: A001-350-032 issue 7

The specification details are illustrative for marketing purposes only. Actual equipment may be different as a result of product improvement or other reasons. Specific interface and performance information should be reconfirmed at time of order placement.