



# Positive Compensation Unit

Perry Slingsby Systems offers a range of positive compensation units ranging from 0.48 litre to 1.75 litre. Larger volume, up to 300 litre, units are available to a different design style.

## Features

- Spring Actuated Rolling Diaphragm
- Available in a Range of Sizes
- Provides Positive Rate Compensation



480cc Compensation Unit

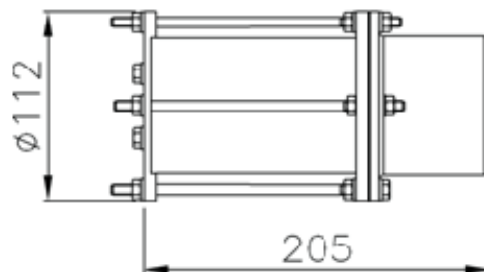

1.75L Compensation Unit

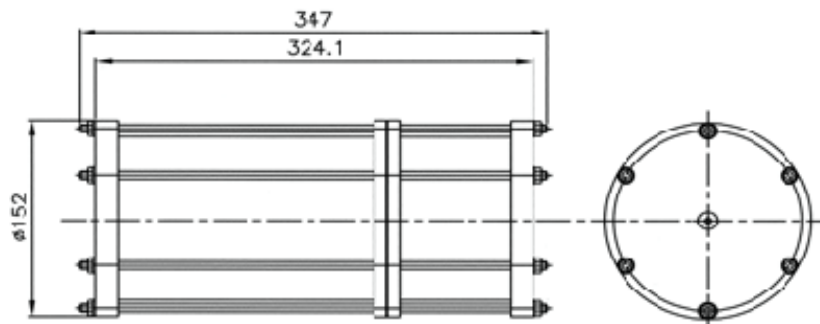

### 875cc Compensation Unit

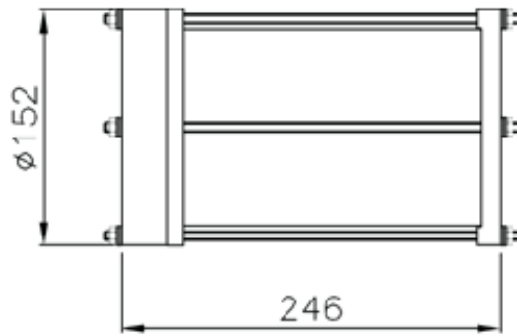

## Specification

Type: Spring Actuated Rolling Diaphragm  
Oil Capacity: 0.48L, 0.875L, 1.75L, 3.3L, 7.2L, 11L, 22L  
Positive Compensation: 0.3 Bar (5 psi) Max  
Options: Integral Contents Level Sensor  
Hydraulic Fittings: JIC or Swagelok

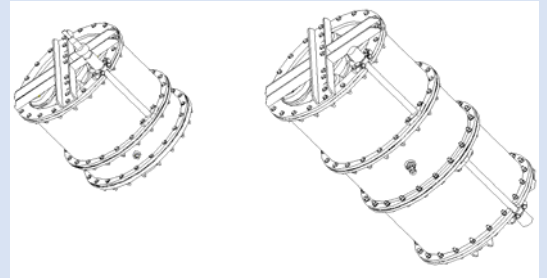

Type: Airspring Bellows Type  
Oil Capacity: 35L, 300L  
Options: Integral Contents Level Sensor  
Hydraulic Fittings: JIC or Swagelok

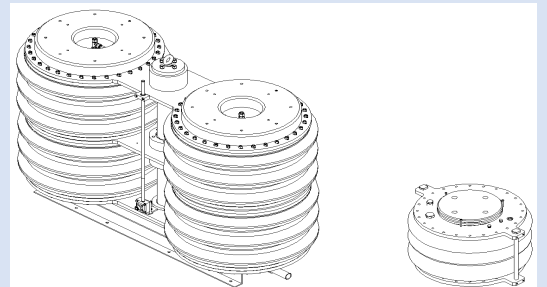

Type: Piston Type  
Oil Capacity: 70L, 90L  
Options: Integral Contents Level Sensor  
Hydraulic Fittings: JIC or Swagelok

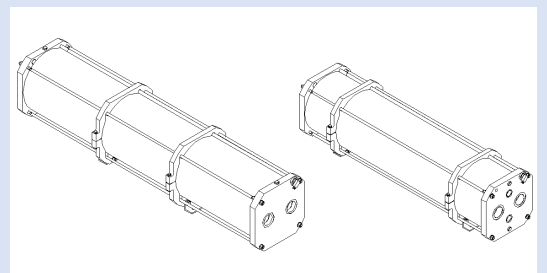

Data Sheet: A001-350-017 Issue 8

The specification details are illustrative for marketing purposes only. Actual equipment may be different as a result of product improvement or other reasons. Specific interface and performance information should be reconfirmed at time of order placement.