



Class 1-4 Gauging Tool

The Class 1-4 Gauging Tool has been developed to test interfaces. The interfacing part of the tool is identical to the Class 4 Torque Tool and comes with a set of class 1-4 sockets as standard. This allows rapid interface checks without the weight and hydraulic requirements of using a real torque tool.

The tool can be turned by hand from a handle at the rear, or can be fitted with a shaft at the rear to accept a torque wrench, so that torque can be applied to the valve. Locking wings are provided to check the latching operation.

Features

- Used to check ISO Class1-4 Interface
- Latching Wings
- Rotating Socket
- Lightweight

Standard Tool

Part # A019-958-452



Dimensions

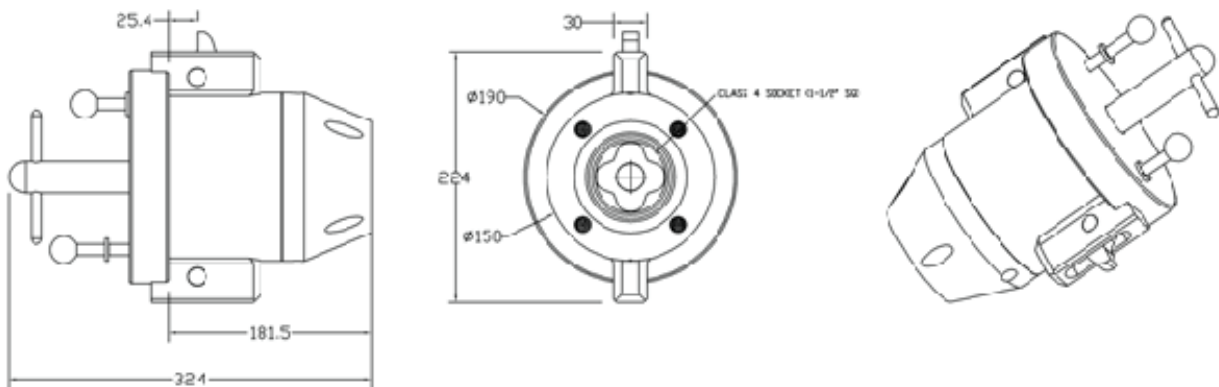

Data Sheet: A001-350-007 issue 7

The specification details are illustrative for marketing purposes only. Actual equipment may be different as a result of product improvement or other reasons. Specific interface and performance information should be reconfirmed at time of order placement.