



TA19 Hydraulic Cable Cutter

The Cable Cutter is designed to sever subsea umbilicals including armouring, up to 100mm in diameter. The cable is trapped by an anvil rod and then cut by a blade. The anvil and blade are driven hydraulically in both directions.

The body is constructed from marine grade aluminum alloy giving a total weight suitable for ROV manipulator deployment. A deployment handle is provided.

The cable cutter is fitted with a hydraulic connection to the host ROV for operation. An optional 'Emergency' disconnect mechanism can be supplied which will release it from the host ROV in case there is a loss of power.

Features

- Cuts Cables up to Ø100mm
- Lightweight
- ROV Deployed
- Industry Standard Tool

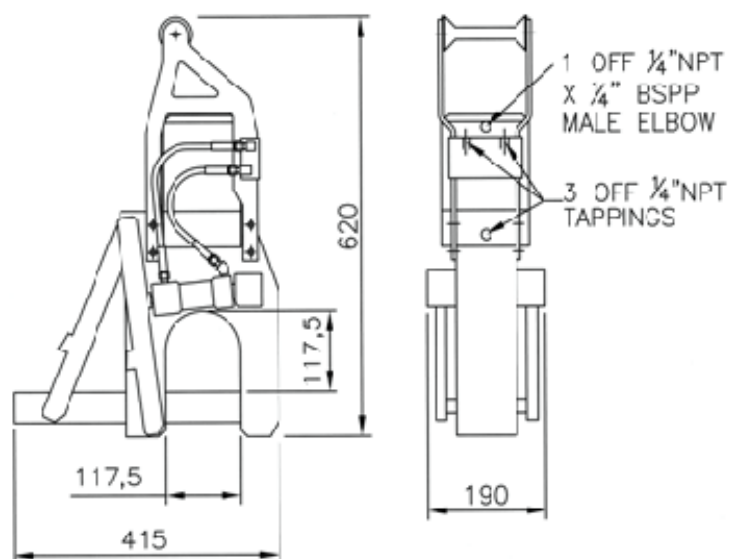
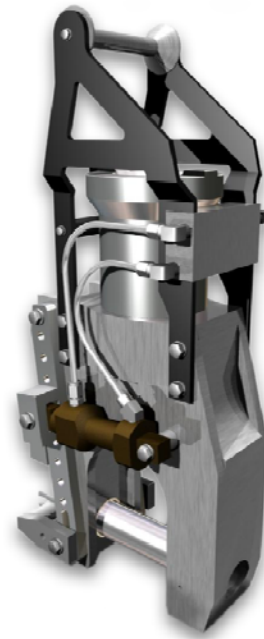

Interface Requirements

The cutter assembly has an integral handle, which has been designed for interface with most parallel or intermeshing manipulator jaw sets. The tool itself requires 4 hydraulic service connections – 2 off 1/4" NPT to the anvil open / close actuators, 1 off 1/4" BSPP to the full bore side of the blade actuator and 1 off 1/4" NPT to the annulus side of the blade actuator. The cutting function requires a pressure intensification unit.

Specification

Cable Diameter:	100mm Max
Cable Type:	Armoured or Lightweight Umbilicals
Max Hydraulic Pressure:	700 Bar-Main Cut (Requires Pressure Intensifier) 190 Bar-All Other Functions
Hydraulic Fluid:	Mineral Oil
Weight:	30kg
Weight in Water:	23kg
Length:	415mm
Width:	190mm
Height:	620mm Overall

Data Sheet: A001-350-004 issue 7

The specification details are illustrative for marketing purposes only. Actual equipment may be different as a result of product improvement or other reasons. Specific interface and performance information should be reconfirmed at time of order placement.